

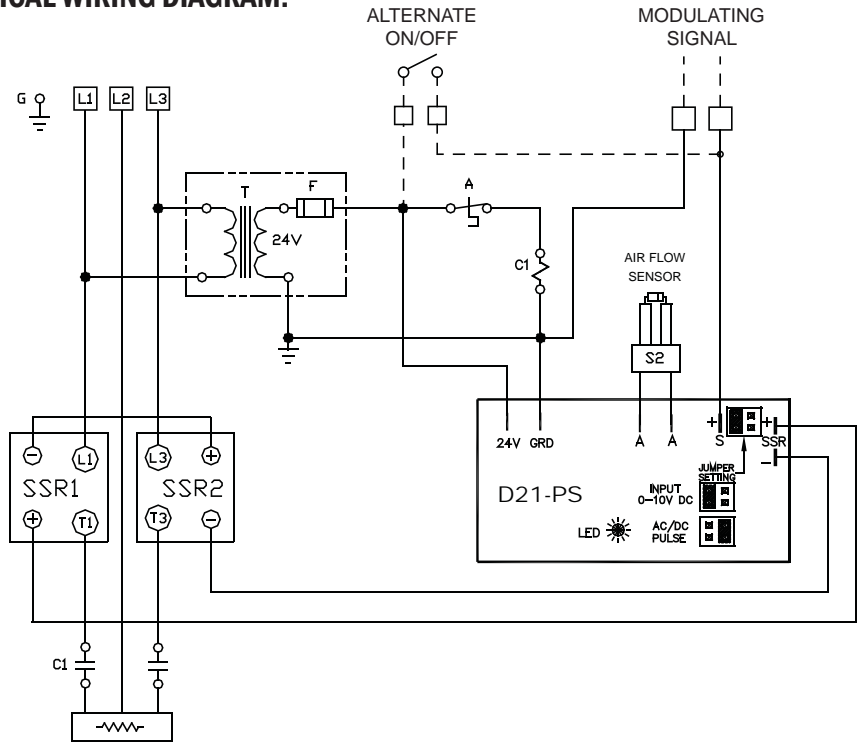

The **D21-PS** electronic controller has been designed to take full advantage of our patented Air-Flow Sensor which modulates the heater's capacity according to the quantity of air flowing through the heater by responding to the radiant heat of the elements even at very low CFMs. With normal airflow the controller will operate at full power. When the airflow drops below the minimum airflow, the controller will still operate but at reduced power. It will also safely shut down the heater in case of a total loss of airflow.

The 'P' versions of controllers such as D21-P, D22-P and D21-PS operate with an input signal of 0 - 10 VDC or AC/DC pulse. It is also possible to adapt the wiring to use a simple ON/OFF contact to turn the controller full on and off.

TYPICAL WIRING DIAGRAM:



To switch the input between 0-10 VDC and AC/DC pulse, simply remove and replace the jumper according to the label. D21-PS controllers may be used to drive up to 4 SSRs. The maximum load is limited to the capacity of the Solid State Relays. In cases with smaller loads, consider the D21-P with a single output and the D22-P equipped with two outputs effectively doubling the capacity of the D21-P.

FEATURES:

- 0-10V DC or AC/DC pulse input
- compatible with electronic Air Flow Sensor
- works with 24 VAC control voltage
- single DC output to control up to 4 SSRs

DIMENSIONS:

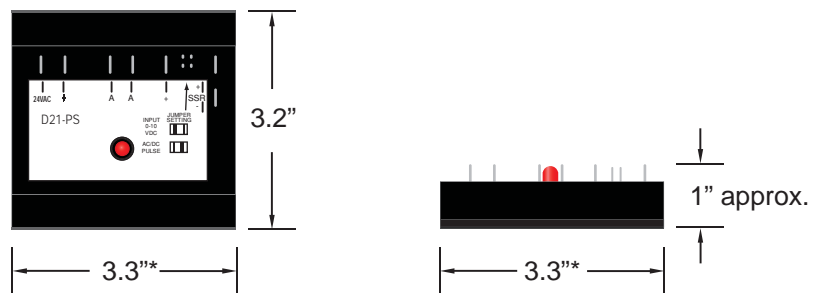

* dimensions are approximate and may change without notice

