

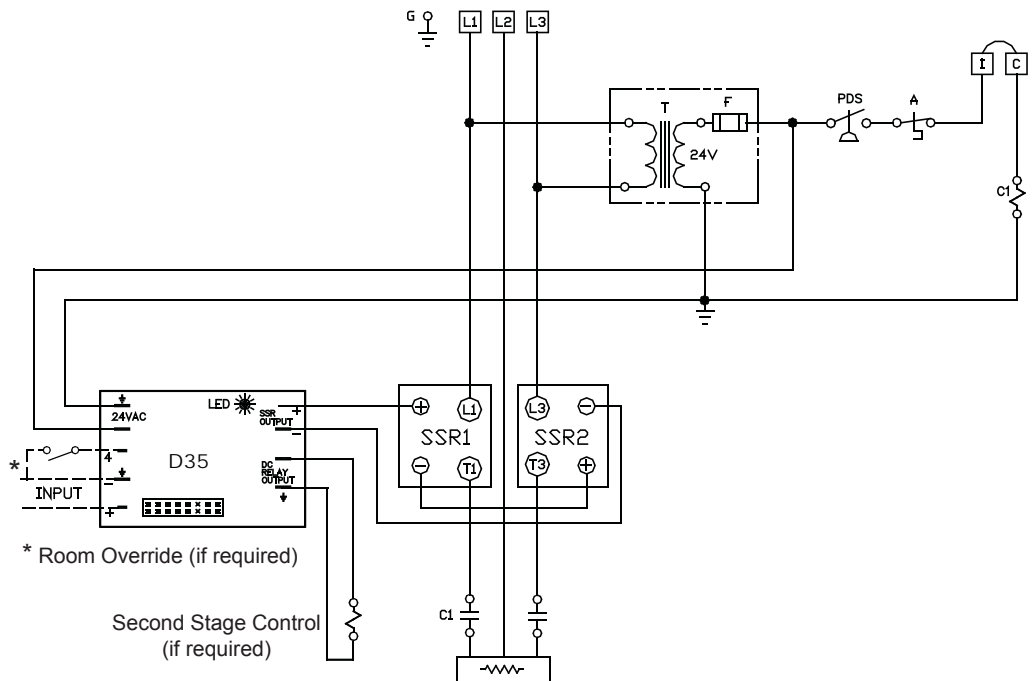

The **D35** pre-calibrated electronic controller is Thermolec's most flexible controller with four different input options on a single board. Jumper configurations are clearly indicated on the label and may be changed at any time. Control signals supported are Thermistor for Thermolec's RT, DT or RADS, 0-135 Ohms, 4-20 mA and 0 - 10 VDC. Since the D35 is not compatible with our Air Flow Sensor it is recommended to be used with a PDS (Pressure Differential Switch) instead.

Other available versions include the **D35-F** with an output to power a fan relay while there is a demand for heat and the **D35-2** which works the same way as the original **D35** except with a 2 - 10 VDC input only.

TYPICAL WIRING DIAGRAM:



FEATURES:

- choice of four types of input on a single board selected by jumper including:
 - Thermistor (RT/DT)
 - 0 - 10 VDC
 - 4 - 20 mA
 - 0 - 135 Ohms
- room override control at 80% of maximum output
- works with 24 VAC control voltage
- single DC output to control up to 8 SSRs
- 24 VDC output for second stage control

The RELAY HYSTERESIS jumper controls the response of the second stage relay output. With the jumper removed the board is set to narrow range, turning the output on when demand is at 70% and off when the demand drops to 60%. For mechanical relays it is recommended to install the jumper for a wide range response where the output is on when the demand reaches 90% and off at 10%. On the D35-F board this output is used for a fan relay instead, where it will stay on continuously when there is a demand and turn off after approximately 12 seconds to dissipate the heat after the elements stop.

DIMENSIONS:

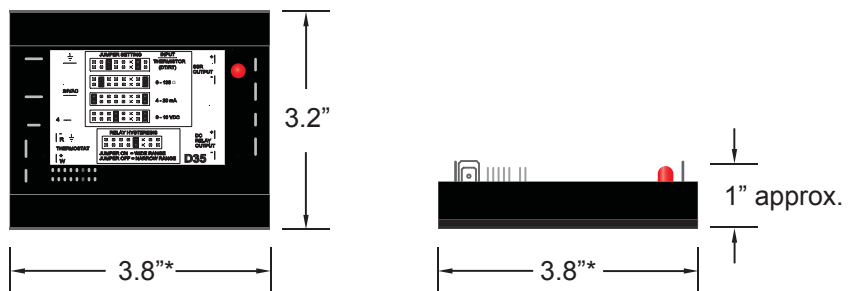

* dimensions are approximate and may change without notice

